

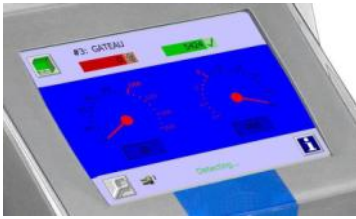

IQ³⁺ Metal Detector Search Heads

www.loma.com

Adaptable and tough, variable frequency metal detection systems for the food and packaging industries. With full colour graphical touch screen



Operator screen with Performance Validation countdown timer, which assists in HACCP compliance



Context Sensitive help screens, ensures compliance with internal quality standards for testing and validation

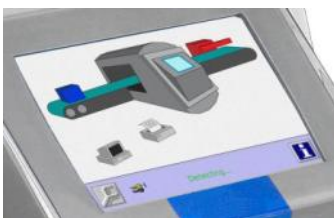

Icon Driven Menus simply touch the relevant Icon for set up or adjustment



- **Adaptable** True variable frequency detection adapts to new product and packaging in seconds
- **Easy to use** Automatic product learn ensures maximum sensitivity without adjustment
- **Stable** Unique case and coil geometry delivers unsurpassed levels of immunity
- **Flexible** Multiple product memories for rapid product change over and data storage
- **Tough** IP69K environmental protection

Metal Detection

X-ray Inspection

Checkweighers

Data Capture

Designed to Survive



Metal Detector Search Heads

Finish:	304 stainless steel with brushed finish	
Supply Voltages:	100, 120, 200, 220, 230, 240V AC 50/60Hz	
Power Consumption:	20VA	
Temperature Range:	-10°C to +35°C (14°F to 95°F)	
Humidity:	0 to 95% Relative Humidity (non-condensing)	
Reject Options:	Air Blast single or twin, Pusher others to order	
Environment:	IP 69K	Blue Head
	IP 69K Ultra Harsh	MAX
Options:	Beacon stanchion	Reject confirm
	LomaEnet	Bin full
	Serial link	Remote reports
	PVS (Performance Validation System)	



Technical Specification

- Unique clam-shell design case and coil geometry
- Bifurcated and totally uniform product screen
- Upgradeable metal detector controls
- True variable-frequency, standard operating range from 40 to 900KHz
- Performance Validation System (PVS) to aid HACCP compliance
- Various communication options to suit plant integration protocols
- 32-bit digital signal processing for enhanced contaminant detection

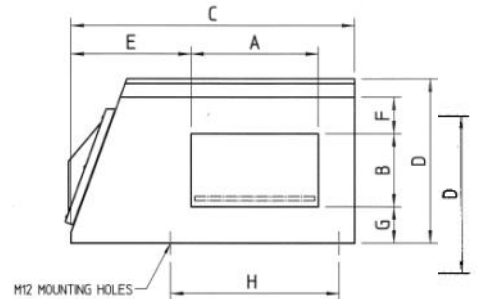
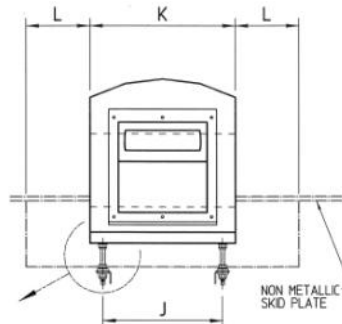

- Standard apertures on rapid delivery
- Extensive on board reporting facilities meaning HACCP and retailer compliant, Ethernet and OPC compatible

Data and product backed up and stored via USB

Height mm

100 150 200 250 300 350 450

Width mm

250 350 450 550 650 750 950 1150

*Other aperture sizes available

DIMENSION A - APERTURE WIDTH
DIMENSION B - APERTURE HEIGHT

B	75	100	125	150	175-250	275-350	375-450	475-550
C	A+430	A+430	A+430	A+430	A+430	A+530	A+670	A+810
D	392.5	392.5	392.5	400	B+250	B+350	B+450	B+550
E	330	330	330	330	330	380	470	560
F	125	112.5	100	100	100	150	200	250
G	142.5	130	117.5	100	100	150	200	250
H	A+114	A+114	A+114	A+114	A+114	A+114	A+114	A+114
J	230	230	230	230	330	430	530	630
K	300	300	300	300	400	500	600	700
L	75	75	75	75	175	275	350	450



Inspection Systems Pty. Ltd.

Melbourne - Sydney - Brisbane - Perth - New Zealand

Freecall: 1800 354 302

E-mail: info@inspectionssystem.com.au

Web: www.inspectionssystem.com.au

product inspection machinery specialists